

A Study towards Applying Thermal Inertia for Energy Conservation in Rooms

YI YUAN, The Hong Kong Polytechnic University
DAWEI PAN, Harbin Institute of Technology
DAN WANG, The Hong Kong Polytechnic University
XIAOHUA XU, Illinois Institute of Technology
YU PENG, Harbin Institute of Technology
XIYUAN PENG, Harbin Institute of Technology
PENG-JUN WAN, Illinois Institute of Technology

Yi Yuan and Dan Wang are with The Hong Kong Polytechnic University Shenzhen Research Institute, Shenzhen 518057, China, Emails: {csyiyuan, csdwang}@comp.polyu.edu.hk; Dawei Pan, Yu Peng, and Xiyuan Peng are with Automatic Test and Control Institute, Harbin Institute of Technology, China, Emails: tianxi-apdw@163.com, {pengyu, pxy}@hit.edu.cn; Xiaohua Xu and Pengjun Wan are with Department of Computer Science, Illinois Institute of Technology, USA, Emails: {xxu23, wan}@iit.edu.

A preliminary version of the paper appears in the Proc. of IEEE INFOCOM 2012, Orlando, FL, March, 2012. Permission to make digital or hard copies of part or all of this work for personal or classroom use is granted without fee provided that copies are not made or distributed for profit or commercial advantage and that copies show this notice on the first page or initial screen of a display along with the full citation. Copyrights for components of this work owned by others than ACM must be honored. Abstracting with credit is permitted. To copy otherwise, to republish, to post on servers, to redistribute to lists, or to use any component of this work in other works requires prior specific permission and/or a fee. Permissions may be requested from Publications Dept., ACM, Inc., 2 Penn Plaza, Suite 701, New York, NY 10121-0701 USA, fax +1 (212) 869-0481, or permissions@acm.org.

© 20YY ACM XXXX-XXXX/20YY/05-ARTXX \$10.00

DOI 10.1145/0000000.0000000 <http://doi.acm.org/10.1145/0000000.0000000>

We are in an age where people are paying increasing attention to energy conservation around the world. The heating and air-conditioning systems of buildings introduce one of the largest chunks of energy expenses. In this paper, we make a key observation that after a meeting or a class ends in a room, the indoor temperature will not immediately increase to the outdoor temperature. We call this phenomenon *Thermal Inertia*. Thus, if we arrange subsequent meetings in the same room; rather than a room that has not been used for some time, we can take advantage of such un-dissipated cool or heated air and conserve energy. Though many existing energy conservation solutions for buildings can intelligently turn off facilities when people are absent, we believe that understanding of thermal inertia can lead system designs go beyond on-and-off based solutions to a wider realm. In this paper, we give an experience towards this direction.

We propose a framework to explore thermal inertia in room management. Our framework contains two components: 1) Energy-Temperature correlation model. This model captures the relation between indoor temperature change and energy consumption. 2) Energy-aware scheduling algorithms. Given information for the relation between energy and temperature change, energy-aware scheduling algorithms arrange meetings not only based on common restrictions such as meeting time and room capacity requirement, but also energy consumptions. We identify the interface between above components so further works towards same direction can make efforts on individual component.

We develop a system to verify our framework. First, it has a wireless sensor network to collect indoor, outdoor temperature and electricity expenses of the heating or air-conditioning devices. Second, we build an energy-temperature correlation model for the energy expenses and the corresponding room temperature. Third, we develop room scheduling algorithms. In detail, we first extend the current sensor hardware so that it can record the electricity expenses in re-heating or re-cooling a room. As the sensor network needs to work unattendedly, we develop a hardware board for long range communications so that the Imote2 can send data to a remote server without a computer-relay close-by. An efficient two tiered sensor network is developed with our extended Imote2 and TelosB sensors. We apply laws of thermodynamics and build a correlation model of the energy needed to re-cooling a room to a target temperature. Such model requires parameter calibration, and uses the data collected from the sensor network for model refinement. Armed with the energy-temperature correlation model, we develop an optimal algorithm for a specified case. And we further develop two fast heuristics for different practical scenarios.

Our demo system is validated with real deployment of a sensor network for data collection and thermodynamics model calibration. We conduct a comprehensive evaluation with synthetic room and meeting configurations; as well as a real class schedules and classroom topologies of The Hong Kong Polytechnic University, academic calendar year of Spring 2011. We observe a 20% energy saving as compared with the current schedules.

Categories and Subject Descriptors: C.2.2 [To do]: To do

General Terms: Design, Algorithms, Performance

Additional Key Words and Phrases: Thermal Inertia, Energy Conservation, Wireless sensor networks, Room management

ACM Reference Format:

Y.Yuan, D.Pan, D.Wang, X.Xu, Y.Peng, X.Peng, P.Wan. 2012. A Study towards Applying Thermal Inertia for Energy Conservation in Rooms. *ACM Trans. Sensor Networks*. XX, XX, Article XX (May 20YY), 26 pages. DOI = 10.1145/0000000.0000000 <http://doi.acm.org/10.1145/0000000.0000000>

1. INTRODUCTION

There is a huge interest in building a green world recently. The key focus is energy conservation and energy efficiency. Computer scientists are actively contributing our effort in two directions, 1) improve energy efficiency of computing systems, and 2) apply computing systems (e.g., sensor networks) for energy conservation in broader disciplines.

For the first category, many studies are working on energy efficiency for data centers [Raghavendra et al. 2008][Shang et al. 2010], a top energy consumer among all computing devices. While the energy expenses of computing industry is increasing fast in recent years, the largest portion of energy consumption is still dominated by such areas as commercial buildings, residential usage, transportation, manufactory industry [USEnergy 2010]. Especially, for regions where the industrial sector is small, the

electricity consumption by commercial buildings can be more dominating; for example in Hong Kong, 65% of electricity in 2008 goes to the commercial sector [HKE 2010].

The heating and air conditioning of commercial buildings has the largest chunk in energy expenses. In 2008 the Office Segment of Hong Kong, 54% electricity goes to space conditioning (i.e., air-conditioning), 14% goes to lighting, 13% goes to office equipments such as computers [HKE 2010]. Monitoring the conditions of the buildings and efficient utilization of heating, ventilation, and air conditioning (HVAC) has been a long time topic; and advanced commercial buildings can automatically turn off lights and HVAC systems of rooms when humans are not in presence. Nevertheless, we notice that even if the heating or air-conditioning of a room is turned off, the heat or the cool air will not immediately dissipate. We call this phenomenon *Thermal Inertia*.¹ We consider the un-dissipated cool or heated air a valuable resource that can be utilized, so that future usage of this room can take the advantage without re-heating or re-cooling the room. We believe that an understanding and application of thermal inertia is very helpful as this can lead system designs go beyond the existing turning facilities on-and-off based solutions to a wider realm.

Based on this thermal inertia, we propose an energy conservation room management system. In this system, the allocation of the rooms of a building (or classrooms in campus) is based not only on a schedule (e.g., meeting time, room capacity, facility requirement), but also on the existing heating or air-conditioning conditions of the rooms. In the rest of the paper, we will only use air-conditioning as an example to ease our presentation. There will be only re-cooling energy analyzed instead of re-heating/re-cooling in later analysis.

Our room management systems falls into an optimization problem with the objective as minimizing the re-cooling energy consumption while satisfying all meeting requirements (e.g., meeting time, room capacity, facility requirement). It is not straightforward, however to know how much energy will be saved if a room is scheduled. As an example, consider that the office temperature in Hong Kong is 26°C (79°F). Assume a room was used 20 minutes ago, and its current temperature is 29°C (84°F). The outdoor temperature is 37°C (99°F). If we schedule a meeting 5 minutes later in this room, how much electricity is needed to re-cool it to the targeted temperature 26°C (79°F)? Quantification of such question is essential for room scheduling decision making, i.e., when we have to face a selection among multiple possible rooms. Thus we need an *energy-temperature correlation model* to assist room scheduling. The correlation between energy consumption and indoor temperature change is affected by such factors as the room specifics (size, wall materials, etc), current indoor temperature, outdoor temperature and the targeted temperature etc. A key difficulty for building an energy-temperature correlation model is to capture the correlation among these factors. The more accurate this correlation model is, the better energy conservation scheduling result we can get on top of it. Building this model does not solely fall into the computer science domain. Advanced thermodynamics theories may be needed.

After some studies on thermodynamics field, we abstract a framework for an energy conservation room management system. This framework contains two components: 1) An energy-temperature correlation model. This model offers energy consumption information to assist scheduling decision making. We summarize three methods which can be used to implement an energy-temperature correlation model component. 2) Energy-aware schedule algorithms. These algorithms schedule meetings based on not only meeting requirements, but also information from energy-temperature correlation

¹This name follows a recommendation from a senior practitioner and researcher from Building and Service Engineering.

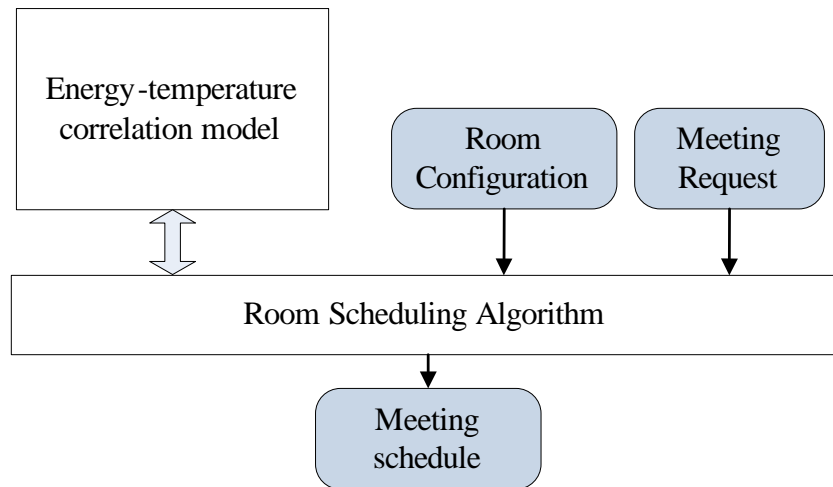

Fig. 1. The framework of the room management system.

model. Moreover, we formally state our problem and prove it is NP-complete to find a schedule which consumes the minimum energy.

We develop a system to verify our framework. When developing an energy-temperature correlation model, we apply rudimental thermodynamics theory to build a simple initial energy-temperature correlation model and calculate main parameters from sensor data. We validate the effectiveness of such design by real experiments. Based on the energy-temperature correlation model, we develop room scheduling algorithms. We first develop an optimal algorithm for a special case where all rooms are equal. For the general case, we develop two efficient heuristics. Besides a real world system deployment for model validation and data collection, we evaluate our system with comprehensive simulations with synthetic room configurations and meeting schedules. We also evaluate our algorithms with real class schedules and classroom topologies of The Hong Kong Polytechnic University, academic calendar year of Spring 2011. We observe that we can save 20% of electricity as compared to the current room schedules. In the annual simulation, we can save 15% in winter and 26% in summer.

The remaining part of the paper proceeds as follows. We discuss the framework in section 2 and give an overview to our system in section 3. In section 4, we present our design of the sensor network. Section 5 is devoted to our energy-temperature correlation model and real world experiment validations. We detail our room scheduling algorithms in section 6. In section 7, we evaluate our algorithm comprehensively. We present related work in section 8 and conclude the paper in section 9.

2. FRAMEWORK FOR ENERGY CONSERVATION ROOM MANAGEMENT SYSTEM

In this section, we first introduce our framework for energy conservation room management system. Then we formally state our problem for finding schedule with minimum energy consumption and prove it is NP-complete. Finally, we introduce methods for developing energy-temperature correlation model.

2.1. Framework

The high-level framework for an energy conservation room management system is in Fig. 1. As a first work, we confine our study that given the schedules, how the class/meetings should be arranged. We leave a detailed investigation of online room

management as future work. We assume that times for all meetings are known. We schedule meetings in order to save energy while meeting requirements such as capacity, facility are still satisfied. We show that minimizing energy consumption for meetings with fixed time is NP-complete, too.

Our system have two main components: 1) an energy-temperature correlation model; 2) energy-aware scheduling algorithms. Room configuration and meeting requests are input into scheduling algorithms. Room configuration contains all rooms' information such as room capacity, facility lists. Every meeting request contains start time, end time, capacity requirement and facility requirement. The output of our system is a meeting schedule.

When scheduling algorithms are processing meeting requests, we arrange meetings in iterations. In every iteration, energy consumption results are offered by interfaces between energy-temperature correlation model and scheduling algorithms. Scheduling algorithms use results from these interfaces to make decisions. The interfaces are specified as follows:

- (1) Re-cooling energy consumption calculation. This interface calculates energy consumed to re-cool a room to target temperature. The result is determined by the physical factors of the room, target temperature of the meeting and time interval between end time of previous meeting in the room and start time of the meeting going to be arranged. We denote this interface as $RE_j(T_t, t')$ where j is room index, T_t is target temperature and t' is time interval between two meeting.
- (2) In-meeting energy consumption calculation. This interface computes energy consumption during the meeting. When a meeting is hold, air conditioner keeps a room at target temperature. In addition to physical factors of the room and target temperature, the result is also related to meeting length. Schedule algorithm use this information to avoid arranging meetings to energy-hungry rooms such as rooms with large capacities. We denote this interface as $E_j(T_t, t)$ where j is room index, T_t is target temperature and t is meeting length.

Because building an accurate energy-temperature correlation model is hard, we isolate the model and scheduling algorithms by these interfaces so that the method used in building energy-temperature correlation model can be improved without affecting the scheduling algorithms. Then energy-temperature correlation model can be improved individually. We discuss choices for developing the model in section 2.3.

2.2. Problem analysis

We formally state the problem. Given a set \mathcal{R} of n rooms and a set \mathcal{M} of m meetings to be scheduled. A meeting $M_i \in \mathcal{M}$ is associated with a time interval (b_i, e_i) and a target temperature T_{ti} , where b_i, e_i represent the start time and the end time of the meeting respectively. Each meeting M_i has a capacity requirement c_i and a facility requirement fr_i which is a set of facilities. A room can only hold one meeting at a time. Room R_j has a capacity C_j . Every room R_j is associated with a function $E_j(T_t, t)$ showing the energy needed to maintain the target temperature T_t for t and a function $RE_j(T_t, t')$ showing the energy needed to re-cool the room to T_t where last meeting has ended for t' . $E_j(T_t, t)$ and $RE_j(T_t, t')$ are computed by the energy-temperature correlation model. We want to find a schedule \mathcal{S} with minimum re-cooling energy consumption while all meeting requirements are satisfied. We call this schedule *Minimum Energy Schedule*.

THEOREM 2.1. *Finding minimum energy schedule is NP-complete.*

PROOF. In order to smooth our presentation, the proof is moved to appendix. \square

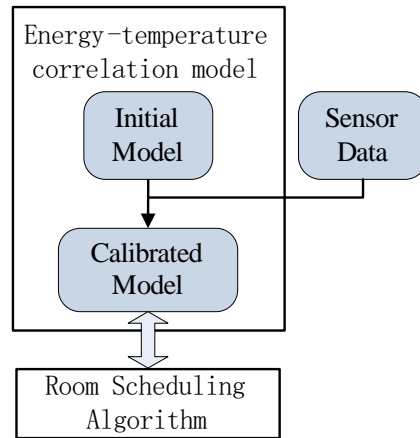

Fig. 2. The third method for building energy-temperature correlation model.

2.3. Energy-Temperature correlation model

To accurately schedule rooms and maximally conserve energy, an important part of an energy-aware room management system is that we need to build an energy-temperature correlation model for every room so that the room scheduling algorithm can run on top of it. More specifically, we need to implement interface $E_j(T_t, t)$ and $RE_j(T_t, t')$ for every room j . There are two extreme ways for building such model. First, we can apply advanced thermodynamics theories and material sciences to explicitly compute such functions. Second, we can build a database with entries of the environment parameters (e.g., indoor temperature, outdoor temperature, and targeted temperature) and the corresponding energy consumptions. In the room scheduling algorithm, whenever an estimation on the energy expenses is needed, an entry in this database that has the most similar environmental configuration can be extracted.

The first choice falls into the expertise of Building and Service Engineering. Given all detailed information about the building (Including location, structure, materials, etc.) and environment information (such as weather data), there are simulation tools such as EnergyPlus [Ene 2010] can be used to calculate energy-temperature correlation. The accuracy of these simulation tools are heavily relied on input information. Uncertainty of building specification can lead to significant errors in the predicted results [Chantrasrisalai et al. 2003][Tian and Love 2009][Zhou et al. 2008].

For the second choice, to build the correlation database, a sensor network can be deployed to collect such data as temperature and energy expenses. The accuracy depends on the granularity of the data collection. The more samples the database has, the more accurate energy expense result it can find for a similar environmental configuration. Building such database needs long time data collection.

There is a third choice which falls into a mixture of the two extremes (See Fig. 2). We use an initial model following rudimental Fourier's law of heat conduction. In this model, some parameters are difficult to compute from theory. These parameters are invariants, however, e.g., only affected by the materials of the room. Thus we inversely calibrate these parameters using data collected by a sensor network.

3. OVERVIEW OF OUR ROOM MANAGEMENT SYSTEM

We build a system to verify our framework. We discuss some high level choices when implementing our room management system. We choose the third method in section 2.3 to build an energy-temperature correlation model because this method captures

parameters from data in a short time data collection. In most cases, we do not have a clear building specification which is important in the first method. And it is also hard to have long-term data collected by a monitoring system installed in the building. The third method is very useful for these scenarios.

When we design the energy-temperature correlation model, we focus on rooms whose energy consumption on air-conditioning can be measured individually. We study single-stage heat pump air conditioner(AC). This kind of AC is widely used in homes to cool a single area. When the AC is in operation, its heat pump runs at a fixed speed. When the AC is not in operation, its heat pump is turned off. The AC turns on and off the heat pump automatically in order to keep indoor temperature at target temperature. We choose single-stage heat pump air conditioner because: 1) Compared with central HVAC systems, it is more accessible; 2) it works for a single room and its electricity consumption can be measured accurately; For central HVAC systems which is common in commercial buildings, it is difficult to measure energy consumption for conditioning every room because the cool air are produced by centralized chillers and distributed to every room by ventiducts. We see the current trend of research is clearly towards a finer granularity in monitoring of electricity consumption, and we believe future researchers may touch this problem separately.

Another choice we make is that we choose electricity expenses, instead of energy expenses, as our optimization metric. Different regions/countries may have different cost on energy. For end-users, having their electricity bills cut could be more attractive as it is directly related to money saving. In addition, we believe that there is positive correlation between the electricity usage and the energy expenses, for example, in 2008, 85% of the energy consumed by commercial buildings in Hong Kong are electricity [HKE 2010]; and a cut in electricity contributes to our effort towards development of greener buildings.

In this system, we consider all meetings have same target temperature. As such, we use $E(t)$ and $RE(t')$ for short.

4. SENSOR NETWORK DESIGN

For a building, or a campus, there are multiple rooms. For each room, we need to build an energy-temperature correlation model (details in section 5) to be used for the scheduling algorithm (details in section 6). As such, a sensor network should be deployed in each room. In this sensor network, there should be a sensor to record electricity usage to air-conditioning the room. We also need to record the temperature. As the temperature in different locations of the room may not be uniform, a set of temperature sensors is suggested. We would like to comment that the sensor network is only used for the construction of the energy-temperature correlation model for each room. After the model is built, we can predict the energy consumption using the model.

Since the sensor network needed in each room is the same, in practice, we can deploy a sensor network and build the energy-temperature correlation model room-by-room.

Our system needs to work unattendedly in a building for a period of time. The sensors can usually be protected by a cover and placed on walls, roofs etc. However, it is impossible to place a laptop computer (as a base station) unattendedly. The rooms are public and the laptop computer can be stolen. This is in contrast to some smart home systems, where we can assume that the laptop/desktop computer will work in a private apartment. As the sensor network is deployed in buildings, power is not as critical as those applications in the wild.

For some functions we need, there is no off-the-shelf component. Before discussing the implementation of our sensor network, we extend the hardware and build an electricity-meter and a long-range data communication module as follows.

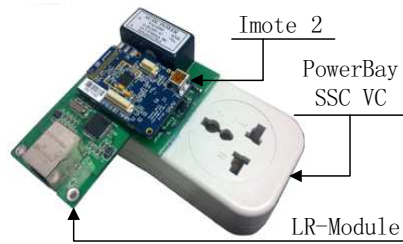

Fig. 3. An Electricity-Meter

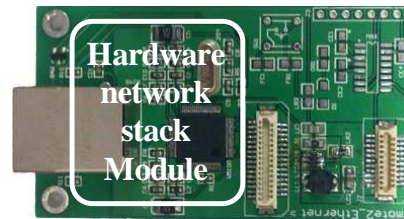

Fig. 4. A Long-range Data Communication Module for Imote2



Fig. 5. The Sensor System. Here we present our enhanced Imote2 node and 3 TelosB temperature sensors.

4.1. Design of an Electricity-meter

Our system needs to estimate the energy consumption for air-conditioning the room to a targeted temperature. We extend Imote2 with a PowerBay SSC VC to record electricity current (see Fig. 3). PowerBay SSC VC also becomes a power supply to Imote2. In operation, PowerBay SSC VC will record the power (in Watt) and such data will be digitized and output to Imote2. The data can then be transmitted out by Imote2.

4.2. A Long-range Data Communication Module for Imote2

We develop a long-range high-rate data communication module (LR-module) for Imote2 (See Fig. 4). This LR-module integrates a hardware network stack and is directly controlled by Imote2 node. Then Imote2 node can send data using TCP connections through an Ethernet port. This choice avoids the high complexity of the network stack and network card driver for the operation system designers, especially for a simple OS like TinyOS.

Equipped with the LR-module, the data can be sent to a remote server, e.g., in practice, we use 3G. Note that the choice of 3G is not special. It is possible to develop a module that use GPRS or WiFi for data transmission. We use 3G as it is more universally applicable than WiFi and has a greater transmission rate than GPRS. In our experiment, the effective data stream throughput of our module can reach 520K bps.

4.3. Development of Sensor Network

We show the design of our sensor network by integrating these components. We develop a two tiered sensor network. The first tier is a set of enhanced Imote2-based electricity-meters. The second tier is a set of TelosB-based temperature sensors (see

Fig. 5). For the first tier, an electricity-meter monitors the electricity usage of the air-conditioner. It is also equipped with the LR-module and can communicate with a remote server. The Imote2-based electricity-meter is powered by alternating current and is thus not energy constrained. For the second tier, we deploy a few indoor and outdoor temperature sensors. We use TelosB, as it is cheaper. To have better flexibility, in practice these temperature sensors can use batteries. TelosB is more energy efficient than Imote2.

The routing architecture of our sensor network is from the temperature sensors to the electricity-meter (one hop). We implement our sensor system in TinyOS, and use Collection Tree Protocol (CTP) [Gnawali et al. 2009] for data routing among sensor nodes. The electricity-meter then sends these temperature data and its electricity readings to a remote server directly (one hop but long range data communication).

The lifetime of our sensor system is determined by TelosB nodes if they use battery power. In practice, every node gets the temperature and transmits 32 bytes every 10 seconds; The projected lifetime of our sensor network can thus reach 2000 hours. We find that this is far enough for us to collect data and calibrate the energy-temperature correlation model.

5. DESIGN OF ENERGY-TEMPERATURE CORRELATION MODEL AND EXPERIMENTAL VALIDATION

In this section, we develop a model where the electricity is a function of current indoor/outdoor temperature and targeted temperature of a room. Our idea is as follows. With our sensor network, we can measure the electricity usage, the indoor and outdoor temperatures and we know the targeted temperature in advance. If there is an artificial perfect room with six identical walls with the same conductivity, we can easily build the energy-temperature correlation model for this room from Fourier's law of heat conduction [Lienhard.IV and Lienhard.V 2003]. We do not have a perfect room, however. Materials, shape and conductivities of the six walls (i.e., four side walls, a ceiling and a floor) are all different. Our key observation is that these factors are invariants. They are determined by their physical materials and do not change (or change ignorably) with outside factors.

Therefore, for each real-world room, we can build a virtual perfect room to mimic it. For this room, we build an energy-temperature correlation model using Fourier's law of heat conduction with the set of invariants undetermined. To compute these invariants, we collect a set of electricity and temperature data by our sensor network. We then inversely derive these invariants. After fitting these invariants back to the model, we use the calibrated model to compute (or predict) electricity usage under any indoor/outdoor temperature and targeted temperature for this room. That is, we have our model.

The concept using a virtual room to imitate a real-world room is widely deployed in the thermodynamic field. In an extensive used tool EnergyPlus[Ene 2010], there is a similar concept *thermal zone*. A thermal zone represents a room space. It is used to catch the thermal factors of this space while ignoring some details of the room. For example, a cuboid thermal zone is introduced to mimic a room space which is not of regular shape. This kind of concept is effective in analyzing a thermal model.

In what follows, we first show the details of the development of our model. Then we display our real-world experiment for validating our method.

5.1. Energy-Temperature Correlation Model

As explained, we use a virtual perfect room where all walls, ceiling and floor are made of materials with the same thermal conductivity and have identical thickness; We show that for any real-world room with different shape and different materials, we

can build a virtual perfect room with uniformed parameters to emulate it. We also assume the electricity-energy transformation rate r is a constant; this indicates when an air-conditioner consumes one unit of energy, the energy injected into a room is constant. In the case of single-stage heat pump air conditioner, this assumption holds naturally because single-stage heat pump runs at a fixed speed.

Table 1. Notation table

Notation	Definition	Unit
T	Indoor temperature	K or $^{\circ}C$
P	Electrical power of the air conditioner	J/s
r	Energy transformation ratio of the air-conditioner	-
P_e	Effective energy injected to the air of the room per second, $P_e = r \times P$	J/s
\tilde{T}_o	Average outdoor temperature of the virtual perfect room	K or $^{\circ}C$
T_o	Temperature outside the real room	K or $^{\circ}C$
T_t	Target temperature of a meeting	K or $^{\circ}C$
k	Thermal conductivity of a material	$W/(K \cdot m)$
L	Thickness of a material	m
A	Total area of six walls	m^2
m	Mass of the air in the room	kg
C	Specific heat capacity of air	$J/(kg \cdot K)$
Q	Heat transfer rate from outdoor to the room	J/s
λ	Conductivity of the room	$J/(s \cdot K)$

Let T be the indoor temperature. Let \tilde{T}_o be the average outside temperature of the virtual perfect room. Let Q be the heat transfer rate from outdoor to the room. Let k be the thermal conductivity of the material. Let A be the total area of the six walls. Let L be the thickness of a material. According to Fourier's law [Lienhard.IV and Lienhard.V 2003], we have

$$Q = \frac{kA}{L}(\tilde{T}_o - T) \quad (1)$$

Eq. 1 basically says that the heat transfer rate is proportional to thermal conductivity of the material, the size of the walls, the temperature difference and is inversely proportional to the thickness of a material. Given a fixed room (material, size and thickness of walls are fixed), this law also tells us that heat transfer rate is proportional to the outdoor/indoor temperature difference. Larger the temperature difference is, more energy we consume on AC in unit time to compensate heat transferred from outside.

Let P_e be the effective energy injected to the air of the room in every second. Let m be the mass of the air of the room. Let C be the heat capacity of the air of the room. In other words, C is the energy needed for one kilogram of a specific material (in our context, the air) to increase one degree of Celsius. The temperature changing rate $\frac{dT}{dt}$ of the room is [Sauer et al. 2001]:

$$\frac{dT}{dt} = \frac{Q + P_e}{mC} \quad (2)$$

Let $\lambda = \frac{kA}{L}$. We say λ as the conductivity of this specific room. Combining Eq. 1 and Eq. 2, we obtain the following function for indoor temperature change:

$$T(t) = \tilde{T}_o + \frac{P_e}{\lambda} + (T(0) - \tilde{T}_o - \frac{P_e}{\lambda})e^{-\frac{\lambda}{mC}t} \quad (3)$$

Note that, Eq. 3 holds only if \tilde{T}_o and P_e can be considered as constants in the time interval from 0 to t . In reality, \tilde{T}_o is effected by the outdoor temperature T_o . Moreover, an air conditioner adjusts its instantaneous power P according to the indoor temperature. Thus P_e varies with time, too. But outdoor temperature and indoor temperature of a room do not change abruptly, so for a short time interval(e.g., ten minutes) we consider \tilde{T}_o and P_e as constants. Because only a few walls of the room are exposed to the open air, \tilde{T}_o is partially related to T_o . We consider the relationship between \tilde{T}_o and T_o as a linear function $\tilde{T}_o = a_0 + a_1T_o$ where a_0, a_1 are constants and $a_1 \in [0, 1]$. If we read T, T_o, P every few minutes, we can change Eq. 3 to following expression:

$$T[n+1] = a_0 + a_1T_o[n] + \frac{r}{\lambda}P[n] + (T[n] - a_0 - a_1T_o[n] - \frac{r}{\lambda}P[n])e^{-\frac{\lambda}{mC}\Delta t[n]} \quad (4)$$

In Eq. 4, n represents the n th reading. $\Delta t[n]$ is the time interval between the n th reading and $(n+1)$ th reading. $T[n]$ is the indoor temperature of the room in the n th reading, $T_o[n]$ is the outdoor temperature and $P[n]$ is the instantaneous power in the n th reading.

The energy-temperature correlation model is Eq. 4 and λ, r, a_0, a_1 are unknown constants. We will first use the sensor data to inversely compute invariants (λ, r, a_0, a_1) . We use $(\hat{\lambda}, \hat{r}, \hat{a}_0, \hat{a}_1)$ to denote them. Then we fit $(\hat{\lambda}, \hat{r}, \hat{a}_0, \hat{a}_1)$ back into Eq. 4 (our energy-temperature correlation model). When future prediction is needed, we use Eq. 4 with $\hat{\lambda}, \hat{r}, \hat{a}_0$ and \hat{a}_1 .

5.2. Parameter identification and re-cooling energy calculation

We observe that in Eq. 4, $T[n+1]$ is in a linear function of $T[n], T_o[n]$ and $P[n]$ if $e^{-\frac{\lambda}{mC}\Delta t[n]}$ is constant. We consider λ as an invariant, because it is related to the physical properties of the materials. And mC is determined by the room size which is fixed, too. Thus if we set all $\Delta t[n]$ as a constant time interval $\tilde{\Delta}t$, we further simplify Eq. 4 as follows:

$$T[n+1] = k_i T[n] + k_c + k_o T_o[n] + k_p P[n]; \quad (5)$$

In Eq. 5, k_i is a constant related to the properties of the room and $\tilde{\Delta}t$. k_c is a constant related to linear function $\tilde{T}_o = a_0 + a_1T_o$. k_o is a constant for indoor temperature change in $\tilde{\Delta}t$ according to outdoor temperature in degree Celsius. k_p is a constant for indoor temperature change introduced by air conditioner in $\tilde{\Delta}t$. The relations between (k_i, k_c, k_o, k_p) and $(\lambda, \tilde{\Delta}t, r, a_0, a_1)$ are in the following equations set:

$$\begin{cases} k_i = e^{-\frac{\lambda}{mC}\tilde{\Delta}t}; \\ k_c = (1 - k_i)a_0; \\ k_o = (1 - k_i)a_1; \\ k_p = (1 - k_i)\frac{r}{\lambda}; \end{cases} \quad (6)$$

If we compute (k_i, k_c, k_o, k_p) from sensor data, we can solve equations set. 6 to get $(\hat{\lambda}, \hat{r}, \hat{a}_0, \hat{a}_1)$. Through the sensor network, we collect indoor temperature sequence $TS_i = (T_{i1}, T_{i2}, \dots)$ for each sensor node i , outdoor temperature sequence $T_oS = (T_{o1}, T_{o2}, \dots)$ and electricity sequence $PS = (P_1, P_2, \dots)$. The time interval between two

ALGORITHM 1: InvariantsCal()

Input: Indoor temperature sequences TS , outdoor temperature sequence T_oS and power sequences PS

Output: $\hat{\lambda}$, \hat{r} , \hat{a}_0 and \hat{a}_1

Step 1:

De-noise TS by wavelet method;

Step 2:

Calculate (k_i, k_c, k_o, k_p) by fitting T_oS , PS and de-noised TS into Eq. 5;

Step 3:

Calculate $(\hat{\lambda}, \hat{r}, \hat{a}_0, \hat{a}_1)$ by solving equation set 6;

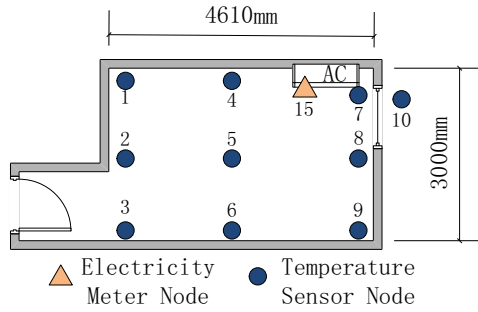

Fig. 6. Experiment Environment in the hotel room

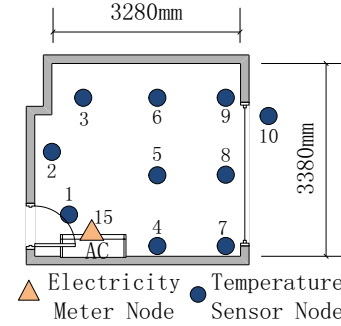

Fig. 7. Experiment Environment in the residential room

reading is constant. We then apply Algorithm InvariantsCal() to calibrate $(\hat{\lambda}, \hat{r}, \hat{a}_0, \hat{a}_1)$. The algorithm has three major steps:

- (1) *De-noise TS* : The readings from each sensor of the sensor network will not be the same in practice even they are in the same room. We follow a common regression model and wavelet method to process the observed data. There are many existing similar methods [Wei 2005], yet wavelet method has been widely used in practice [Li et al. 2002][Goswami and Chan 2011] as it is a powerful tool in time series analysis. We consider the temperature data collected from the sensor nodes as signals containing noises. These signals follow a model $OT(t) = MT(t) + \epsilon(t)$, where $OT(t)$ are the observed temperature data, $MT(t)$ are the main temperature change trend in the room and $\epsilon(t)$ are the noises introduced by location differences of sensor nodes. $OT(t)$, $MT(t)$ and $\epsilon(t)$ are all in function of time t . We then follow the wavelet method using wavelet transform to decompose the observed data into approximated and detailed coefficients and extract $MT(t)$ from $OT(t)$ while eliminating $\epsilon(t)$. We call $MT(t)$ de-noised TS .
- (2) *Compute (k_i, k_c, k_o, k_p)* : We calibrate (k_i, k_c, k_o, k_p) by fitting T_oS , PS and de-noised TS into Eq. 5. Because $T[n+1]$ is in a linear function of $T[n]$, $T_o[n]$ and $P[n]$, we choose least square method as the curve fitting method. Note that, the least square method is not specific. It can be replaced by other curve fitting methods.
- (3) *Calculate $(\hat{\lambda}, \hat{r}, \hat{a}_0, \hat{a}_1)$* : We solve $(\hat{\lambda}, \hat{r}, \hat{a}_0, \hat{a}_1)$ from (k_i, k_c, k_o, k_p) by equations set 6.

5.3. Experiment Validation

We conduct two real experiments to validate our model. It also serves as a test for our sensor network. The first experiment was conducted in a hotel room in Shenzhen, Chi-

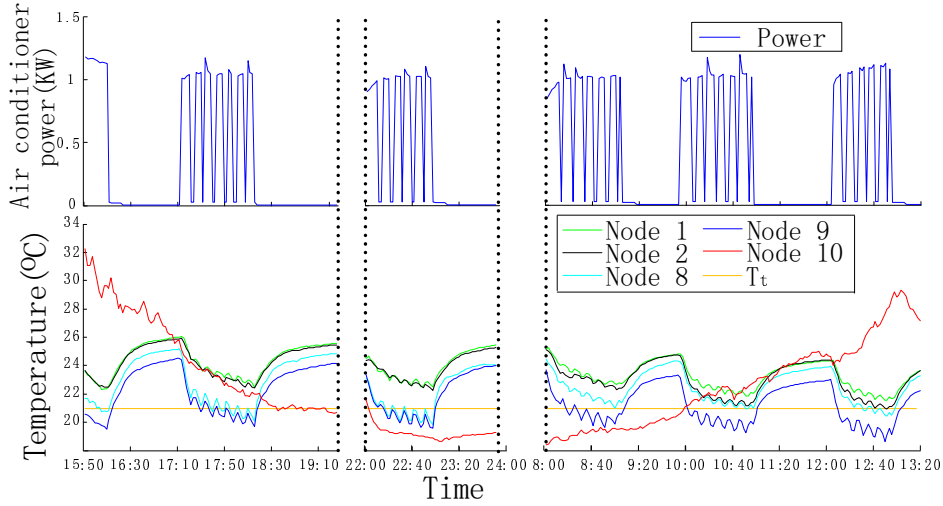

Fig. 8. Experiment Results in the hotel room

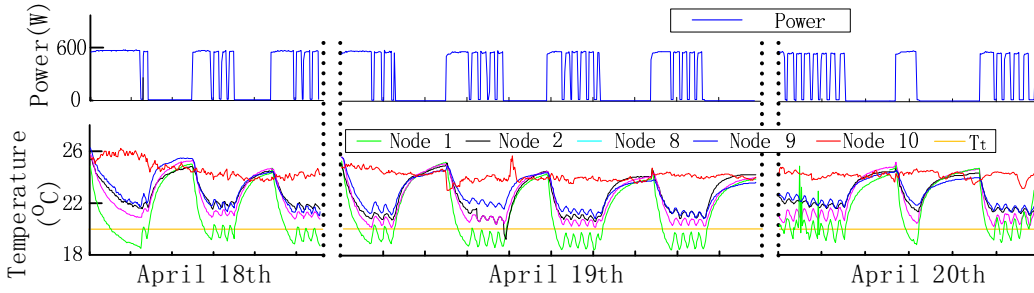

Fig. 9. Experiment Results in the residential room

na from March 2nd to 3rd 2011. The second experiment was conducted in a residential room in Shenzhen, China from April 18th to 20th 2012. The configurations of the room and sensor network are shown in Fig. 6 and Fig. 7 respectively. The configuration of the room and there were nine indoor sensors (No. 1 to No. 9), one outdoor sensor (No. 10) to collect temperature and an electricity-meter (No. 15) connected to the air-conditioner. In all experiments, we periodically turned on and off the AC. Target temperatures are 21°C and 20°C respectively.

In order to measure the accuracy of our energy-temperature correlation model. We choose a period of time (hours or a day). Using our energy-temperature correlation model, we calculate energy consumption to achieve the same indoor temperature change in this periods. We define error as follow:

$$error = \frac{|E_M - E_S|}{E_M} \times 100\% \tag{7}$$

Where E_M stands for measured energy consumption, E_S stands for simulated energy consumption.

The result of the first experiment is shown in Fig. 8. The bottom part of Fig. 8 shows the temperature of four indoor sensors and the outdoor sensor. The upper part of Fig.

8 shows the corresponding output power level of the air-conditioner (in terms of Watt). The second experiment has similar result(See Fig. 9). We can see that the air conditioner turned on and off automatically when the air conditioner tried to maintain the indoor temperature at target temperature.

Using Algorithm InvariantsCal(), we get parameters in the first experiments ($\hat{\lambda} = 28.17, \hat{r} = -0.14, \hat{a}_0 = 23.8, \hat{a}_1 = 0.04$). Then we simulate the energy consumption in five periods (17:10-18:20, 22:00-22:54, 8:00-9:00, 9:50-11:00, 12:05-12:50) when AC is in operation. The result shows that for each period, there is a gap between measured energy consumption and simulated energy consumption. Errors for each periods are 11.5%, 21.1%, 8%, 22.3% and 40% respectively.

We used data from 19th.April to calculate parameters in energy-temperature correlation model and predict the energy consumption in 18th. April and 20th. April. The result (See table II) shows that the daily errors are around 10% which is smaller than errors in the hourly simulation of first experiment.

We admit that only with these experiments, we cannot show that our model can predict re-cooling energy for a long term. We think that it provides reasonable prediction for a short term. This means that we can deploy sensors in each room and continue to monitor the room thermal status to predict future re-cooling energy needed in short term. We emphasize that with the current resource, we only have verification from these two experiment and, though the cases seem acceptable, we admit more experiments are necessary to improve the confidence of this model.

Table II. Measured energy consumption and simulated energy consumption

Predict day	Measured energy consumption (J)	Simulated energy consumption (J)	Error
18th, April	5.319×10^6	4.69×10^6	11.8%
20th, April	3.932×10^6	4.338×10^6	10.8%

We want to further emphasize that after we have the energy-temperature correlation model, we do not need the sensor network in the room. Our experience shows that to build the model, it is enough to use the sensor network for a day or few. In our sensor network, TelosB sensors used batteries and the electricity-meter uses alternating current. The energy is not a problem. In addition, though the electricity-meter carries its own data and the temperature data of TelosB sensors, the traffic throughput is also not a problem. It is easy to see that our sensor network can be directly used in other rooms too.

6. ROOM SCHEDULING ALGORITHM

With the energy-temperature correlation model, we are prepared to develop the room scheduling algorithm.

We would like to comment that by no means our intention is to conserve energy needed within meetings. Conservation of such energy is beyond the scope of this paper; but we would like to admit that if the meeting time is long (e.g., three hours), the proportion of the energy that we conserve as compared to the total energy of the meetings can be small. Nevertheless, we are working on one of the most energy consuming sectors of our society. The sheer amount of energy we conserve, as compared to not using our system, is significant.

In this section, we first develop an optimal algorithm when the rooms are uniform. For the general problem with non-uniform rooms, we develop two fast heuristics for different scenarios.

We first define a concept of skyline. It indicates the last time each room is used. Our algorithms will iteratively move the skyline to the end times of the schedule.

ALGORITHM 2: Energy-Aware Room Scheduling (Uniform)**Input:** 1) Meeting set \mathcal{M} ; 2) Room set \mathcal{R} **Output:** Meeting scheduleSort meetings in \mathcal{M} in ascending order of start time; $k_1, k_2, \dots, k_n = 0$; $i = 1$;**repeat** Find R_j and M_i where $b_i - k_j = \min_{R_j \in \mathcal{R}, b_i > k_j} \{b_i - k_j\}$; Schedule M_i in R_j ; $k_j = e_i$; $i = i + 1$;**until** $i = m$;

Definition 6.1. For n room, *skyline* is a set of numbers (k_1, k_2, \dots, k_n) , where k_j is the last time of room R_j usage.

6.1. Algorithm for uniform rooms

We call rooms are uniform if rooms have same capacity and same function $E(t)$ and $RE(t')$. Our algorithm Energy-Aware Room Scheduling (Uniform), Energy-RS(Uniform) for short, is a greedy-based algorithm(See Algorithm 2). We sort the meetings in ascending order based on their starting times. We then group the meetings with the same starting time. Our algorithm performs in iterations, and in each iteration, we handle a group of meetings with the current earliest starting time. We allocate these meetings to the rooms that have ending times that are closest these meetings. We proof the schedule result of algorithm 2 consumes the minimum energy and uses the minimum number of rooms.

Our proof bases on one assumption: $RE(t')$ is a concave function of t' . We believe this assumption is common in nature. In the first few minutes after a meeting ends and AC is off, the difference between indoor temperature and outdoor temperature is big. According to Eq. 1, heat transfer rate is high which results in fast indoor temperature change. When time passes, indoor/outdoor temperature difference is small, indoor temperature increase slowly. We know that re-cooling energy consumption is large when indoor temperature is high and vice versa. Thus changing rate of re-cooling energy consumption decreases when t' increases. In other words, $RE(t')$ is a concave function of t' .

LEMMA 6.2. *Let \mathcal{K} be the set of permutations of numbers k_1, k_2, \dots, k_n . For all $K_i \in \mathcal{K}$, different skyline represented by K_i does not affect later scheduling.*

PROOF. The rooms are uniform, so exchanging the order of rooms does not affect later scheduling. \square

LEMMA 6.3. *Let two uniform rooms R_1 and R_2 have skyline (k_1, k_2) . For two unscheduled meetings $M_1(b_1, e_1)$ and $M_2(b_2, e_2)$, if $k_1 < k_2 \leq b_1 < b_2$, the optimal schedule should put M_1 in R_2 while placing M_2 in R_1 .*

PROOF. The total interval between the scheduled meeting and unscheduled meeting $(b_1 + b_2 - k_1 - k_2)$ is constant. For two uniform rooms, they have same function $RE(t')$. Because $RE(t')$ is a concave function of t' , we have the following inequality: $RE(b_1 - k_1) + RE(b_2 - k_2) > RE(b_2 - k_1) + RE(b_1 - k_2)$. As the total meeting length of M_1 and M_2 is constant, re-cooling energy consumptions determine the difference of total energy consumptions. We conclude it is more energy efficient to put M_1 in R_2 while M_2 in R_1 . \square

THEOREM 6.4. *The total energy consumption by Algorithm Energy-RS(Uniform) is minimum.*

PROOF. We prove by contradiction. For any skyline (k_1, k_2, \dots, k_n) and two unscheduled meeting $M_i, M_h (b_i < b_h)$, M_i is scheduled to R_j where $b_i - k_j = \min_{\forall R_j, k_j \leq b_i} \{b_i - k_j\}$. Assume the contrary holds, it is energy efficient to put M_i in R_l and put M_h to R_j . We have $k_l < k_j \leq b_i < b_h$. This violates lemma 6.3 and 6.2, where it is more energy efficient to put M_i in R_j . \square

THEOREM 6.5. *The total number of rooms scheduled by Algorithm Energy-RS(Uniform) is minimum.*

PROOF. For any skyline (k_1, k_2, \dots, k_n) , M_i is scheduled to R_j in Algorithm Energy-RS(Uniform). Assume there is a minimum room algorithm who puts M_h to R_j and put M_i in R_l . We have $k_l \leq k_j \leq b_i \leq b_h$. Thus, the position of M_h and M_i are interchangeable. And according to claim 6.2, this interchange does not affect the later scheduling. So the schedule result of Algorithm Energy-RS(Uniform) uses as many rooms as the minimum room algorithm. \square

This theorem indicates that Algorithm Energy-RS (Uniform) will select the minimum number of rooms. This is useful for the general algorithm with non-uniform rooms; since we try not to schedule meetings with small capacity requirements into oversized rooms.

6.2. Rooms with Non-Uniform Capacity

6.2.1. Energy-RS(). When rooms have different capacities, we should always use rooms which have smaller capacities because room with bigger capacity always has larger size and re-cooling or maintaining the room at same target consumes more energy. Algorithm Energy-Rs(Uniform) shows us that when arranging meetings in ascending order of start time, it is energy efficient to schedule a meeting to the room which has the closest ending time. Based on these ideas, we develop algorithm Energy-Aware Room Schedule (Energy-RS()). We outline our basic idea. Assume the number of different capacities of all rooms is g . We classify the rooms into different groups $\mathcal{RG}_1, \mathcal{RG}_2, \dots, \mathcal{RG}_g$ according to their capacity. Let GC_k be the room capacity of \mathcal{RG}_k . We have $\forall R_j \in \mathcal{RG}_k, C_j = GC_k$. Assume $\mathcal{RG}_1, \mathcal{RG}_2, \dots, \mathcal{RG}_g$ is sorted in ascending order according to their capacity GC_k . We classify the meeting into different groups $\mathcal{MG}_1, \mathcal{MG}_2, \dots, \mathcal{MG}_g$ according to the capacity requirements of the meetings. For a meeting M_i with a capacity requirement c_i , it is grouped into \mathcal{MG}_k where $GC_{k-1} < c_i \leq GC_k$. As an example, assume the room capacities of all rooms are 20, 40, 60. The meeting requirements are 17, 18, 34. We thus classify the meetings with capacity requirements of 17 and 18 into the group of 20 and the meeting with capacity requirement of 34 into the group of 40.

We schedule meetings of \mathcal{MG}_k into room group \mathcal{RG}_k in ascending order of k . If there is some meetings cannot be scheduled, we move these unscheduled meetings into \mathcal{MG}_{k+1} . When scheduling meetings of \mathcal{MG}_k into \mathcal{RG}_k , we need to make sure facility requirements are satisfied. We first sort meetings in descending order of facility requirement. If meetings have same facility requirements, they are sorted in ascending order of start time. Then we start scheduling with meetings which need the largest number of facilities. In each iteration, we first check whether current meeting can be inserted into the time interval between two arranged meetings in a room. If the meeting can be inserted and the room satisfies meeting's facility requirement, we arrange current meeting in this room. Otherwise, we arrange current meeting to room with closest ending time.

Table III. Room configuration of PolyU

Cap (Seats)	Num	Size ($L \times W \times H, m$)	λ ($J/s \cdot K$)	mC (J/K)	P (W)
20	8	$4 \times 5 \times 3$	49.8	1200	1500
40	42	$8 \times 5 \times 3$	83.7	2400	2400
60	67	$6 \times 10 \times 3$	114.5	3600	4700
80	10	$8 \times 10 \times 3$	142.0	4800	6200
100	4	$10 \times 10 \times 3.3$	175.9	6600	9400
150	17	$10 \times 15 \times 4$	265.0	12000	15600
200	5	$15 \times 14 \times 5$	376.3	21000	21900
300	2	$15 \times 20 \times 6$	540.6	36000	31300

CLAIM 6.6. *The complexity of Algorithm Energy-RS() is $O(nm)$.*

6.2.2. *TimeUr-RS()*. In our framework, each meeting has a capacity requirement and a meeting time requirement. This is the case for many scenarios. For some cases, however, the meeting time can be determined by the room scheduling system. For example, in the class schedule of The Hong Kong Polytechnic University, lecturers does not have two lectures in one day. So lecture times does not need to be fixed at a specified time of a day as long as facility requirements are satisfied.

We propose a simple greedy-based algorithm which allows reassignment of meeting times, we call Time Unrestricted Energy Aware Room Scheduling (TimeUr-RS()). TimeUr-RS() is greedy. It sorts meeting capacities in descending order and then fits meetings into the rooms. Similar to Energy-RS(), for meetings with same capacity requirement, we first arrange ones need the largest number of facilities. This algorithm can be used to provide suggestions for the decision makers, in case there is no compulsory reason to have strict meeting times. In our simulation, TimeUr-RS() is used as a performance comparison.

7. PERFORMANCE EVALUATION

We evaluate our system in two settings. The first one is real class schedules and classroom topologies of The Hong Kong Polytechnic University (denoted PolyU thereafter), academic calendar year of Spring 2011. The second is a set of synthetic room arrangements we generate semi-randomly. For facility requirements, we consider projector, which is commonly used in meetings.

We choose our primary performance metric as the total energy needed to re-cool the rooms to the target temperature for all rooms and all meetings. Note that we exclude the energy needed during the classes, which we cannot conserve. This metric is stable for all room scheduling algorithms.

7.1. PolyU Data

7.1.1. *Simulation setup.* We first study a set of real data from PolyU. PolyU has 155 classrooms (see Table III for the full configurations) and all classrooms have projectors. Because the main purpose of the simulation of HK PolyU data is not to evaluate our modeling for thermal inertia, which we have done in section 5, but to provide a fair input to evaluate the performance of our room scheduling algorithms, we construct models for the classrooms instead of building the models from data in real deployment. We assume that the materials of walls, floors and ceilings of the HK PolyU classrooms are the same to that of the hotel room in section 5.3. Then λ and mC are calculated based on the room size. We also assume single-stage heat pump ACs are used in all classrooms and P is assigned according to the volume of the room.

The default values of our simulation are $\hat{r} = -0.14$, $\hat{a}_0 = 23.8$, $\hat{a}_1 = 0.04$ for all rooms. We set the target temperature $T_t = 20^\circ C$ for all meetings.

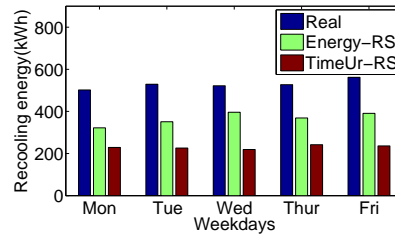

Fig. 10. Re-cooling energy in weekdays

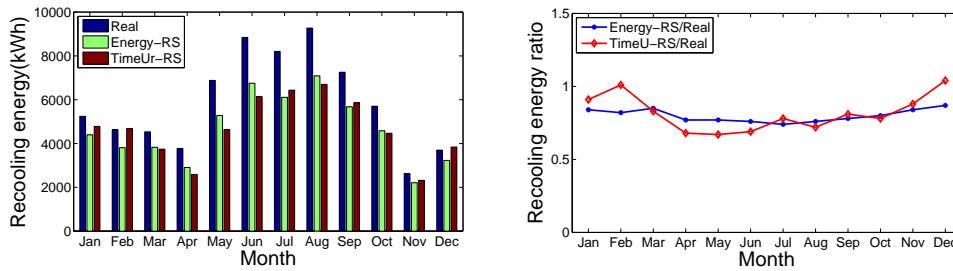

Fig. 11. Monthly re-cooling energy consumption. Fig. 12. Monthly re-cooling energy consumption ratio.

We directly compare the schedules computed by our algorithms (denoted as Energy-RS and TimeUr-RS) with the existing schedule (denoted as Real). We use our model to compute energy consumptions.

To further verify our performance of our algorithms, we conduct a long term simulation with the assists of EnergyPlus. The input of EnergyPlus is a complex building description file (i.e., a model of the building, with room sizes, materials, HVAC schedules, etc) and the output of EnergyPlus is an estimated energy consumption of this building under this configuration. In our simulation, we first construct an artificial building with 155 rooms. Then we use room meeting schedules to configure the HVAC schedules; for example, if a room is in use, the HVAC of this room is on. The building and the HVAC configurations are combined to create the building description file and input into EnergyPlus. We can thus obtain the energy consumption for any meeting schedule for this building. In this simulation, we set target temperatures for cooling and heating as $25^{\circ}C$ and $20^{\circ}C$ respectively. We also compare the three schedules: Real, Energy-RS and TimeUr-RS.

7.1.2. Simulation Result. Though the academic calendar year of Spring 2011 spans for an entire semester, the class schedule for each week is the same. For example, the class schedule of PolyU of every Monday (or any other weekday) is the same in the entire semester. As such, we will only schedule for five weekdays and our schedule can be used in every week of the semester.

Fig. 10 summarizes the results from our model. We can see that every day the re-cooling energy needed is approximately the same. This is because the total classes in different weekdays are more or less the same, which is the usual case of a university.

We also see a general 20% conservation in electricity for each weekday. If there is less restriction in class time, then we will achieve higher energy conservation.

The monthly simulation result from EnergyPlus is shown in Fig.11. From May to October, all schedules consume a lot of energy. This is because Hong Kong is a subtropics city and it has a long summer. In April and November, because the outdoor temperatures in days are about $20^{\circ}C$ to $25^{\circ}C$, so there is less need for cooling and heating. The energy consumptions in this two months fall to the valley. We also see big energy consumptions in January, February and March. The energy consumption in this period are used for heating.

Next, we compare the energy consumptions in different schedules. Compared with real schedule in PolyU, both Energy-RS and TimeUr-RS saves about 14700 kWh in one year, which is 20% of the annual energy consumption of current schedule. In detail (See Fig.12), Energy-RS saves about 15% in winter months. In summer months, the proportion of conserved energy increases and reaches the submit 26% in July. TimeUr-RS show different trends. In most of the cases, TimeUr-RS saves more energy than Energy-RS. But in winter months(January, February, December), the energy consumed by TimeUr-RS is more than energy used by Energy-RS. And it is even higher than consumption of real schedule in January and December. We think the reason for these results is that when TimeUr schedule meetings, it will arrange meetings starting from the early morning. Outdoor temperature in the morning is lower than temperature at noon. In summer, arranging meetings in early morning will save energy for cooling rooms, But in winter, this decision costs more energy to heat rooms. From this result, we find outdoor temperature change should be considered when we are deciding whether to arrange meeting as early as possible.

7.2. Synthetic Data

7.2.1. Simulation setup. For synthetic data, we choose to compare our algorithm with an ad-hoc room scheduling algorithms (denoted as *RS*) that can satisfy the meeting time, room capacity requirements and facility requirements. Though there are different classroom scheduling algorithms, there is no algorithm with an objective or constraint on energy considerations. As our paper focus on energy conservation, it is our intension to simplify the room scheduling algorithms. The ad-hoc room scheduling algorithm is a greedy algorithm where we schedule each incoming meeting request to the smallest room available that can entertain such request.

We consider rooms with uniform capacity and non-uniform capacity separately. For the uniform case, the default room capacity is 100 seats and the total number of rooms is 150. The meeting times are randomly generated in range [8:00, 22:00]. The lengths of the meetings are randomly chosen from a few fixed options, as we believe most meetings have semi-fixed length. We have three options, $\mathcal{O}_1 = [1, 1.5, 2, 2.5, 3]$, $\mathcal{O}_2 = [1, 2, 3]$, $\mathcal{O}_3 = [1, 2]$. That is, for \mathcal{O}_1 , the meeting lengths are randomly chosen from one of the five choices, 1, 1.5, 2, 2.5, or 3 hours.

For the non-uniform capacity case, we have eight different types of rooms with capacities of 20, 40, 60, 80, 100, 150, 200, 300 (similar to PolyU). The numbers of different types of rooms follow a Poisson distribution with a mean of 3. This indicates that the majority of our rooms are those with capacity of 60 seats. The total number of rooms is also 150. There are 70 projectors uniformly distributed among the rooms. The meeting times are randomly generated in range [8:00, 22:00]. The length of the meetings are also from the three options, \mathcal{O}_1 , \mathcal{O}_2 , and \mathcal{O}_3 . The capacity requirement for the meetings follows a poisson distribution with a mean of 3. The facility requirements follow a standard uniform distribution.

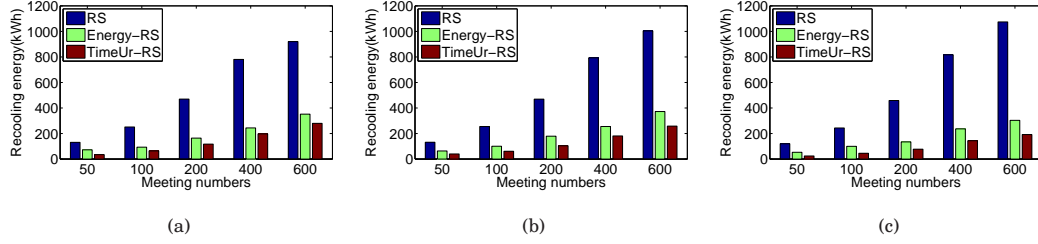

Fig. 13. Total energy expense for re-cooling the rooms as against to the number of meetings; rooms with uniform capacity. (a) meeting length: option \mathcal{O}_1 , (b) meeting length: option \mathcal{O}_2 , (c) meeting length: option \mathcal{O}_3 .

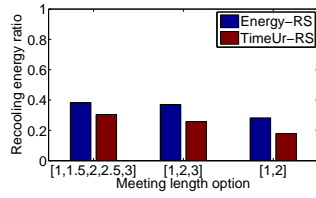

Fig. 14. Re-cooling energy ratio.

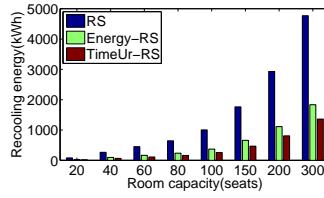

Fig. 15. Re-cooling energy as against room capacity

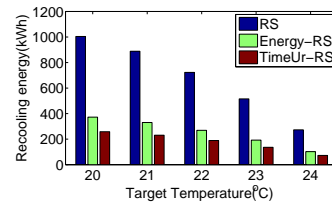
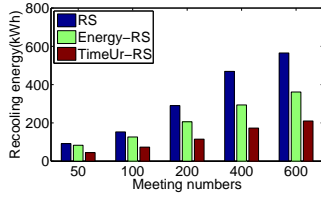
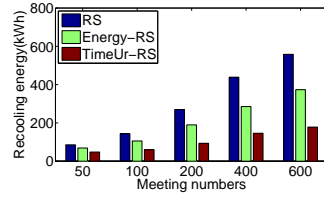

Fig. 16. Re-cooling energy as against target temperature.



(a)



(b)

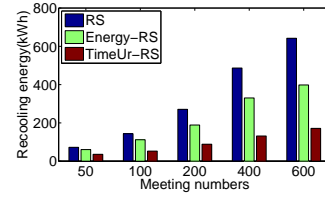

(c)

Fig. 17. Total energy expense for re-cooling the rooms as against to the number of meetings; rooms with non-uniform capacity. (a) meeting length: option \mathcal{O}_1 , (b) meeting length: option \mathcal{O}_2 , (c) meeting length: option \mathcal{O}_3 .

7.2.2. Simulation Result. In Fig. 13, we show the total energy for re-cooling the rooms for different algorithms. In Fig. 13 (a), we see that the re-cooling energy needed for ad-hoc room scheduling RS is always greater than our algorithm Energy-RS and TimeUr-RS. This is not surprising as the RS only satisfies the meeting requirements. When the number of meetings increases, we can see that all three algorithms need more energy in re-cooling the rooms. This is because there are more meetings and more rooms to be used. RS increases much faster than our algorithms, however; as both of our algorithms have taken the energy conservation into consideration. More specifically, we can see that if there are 600 meetings to schedule, the total electricity needed by RS, Energy-RS and TimeUr-RS is 920 kWh, 351 kWh, and 279 kWh respective. We can see that we have reduced the electricity consumption for more than half. If the meeting

time is not restricted, we can make a suggestion on meeting times so as to reduce the electricity consumption to less than one third.

We then see Fig. 13 (b) and (c) where the meeting time is randomly chosen from \mathcal{O}_2 and \mathcal{O}_3 . We see similar trend as that in Fig. 13. We also see that the less number of choice that we have in meeting time, the greater the benefit of our algorithms. This is because if there is a smaller number of meeting length options, there is also a smaller number of small time segments that we cannot fit the meetings in due to more irregular meeting time length. On the contrary, we do not see improve for RS as its schedule is ad-hoc.

This can be more clearly seen from Fig. 14. We call the re-cooling energy ratio as the re-cooling energy needed by Energy-RS (or TimeUr-RS) as against to the re-cooling energy needed by RS. In Fig. 14, we plot the re-cooling energy ratio for the case where the number of meetings is 600. We can see that when the meeting lengths become more uniformed, the re-cooling energy ratio of Energy-RS and TimeUr-RS becomes smaller. This suggests that to save more energy, it is better to have the meeting length more uniform.

The energy consumption is closely related with the target temperature. We adjust the target temperature T_t from 20°C to 24°C. From Fig. 16, we see that every degree counts! For example, the re-cooling energy is around half if we increase our target temperature from 20 to 23. This suggests that the best way to save energy is to set the temperature bar higher. Our algorithm again significantly outperforms RS.

Fig. 15 shows re-cooling energy needed when we use different room capacity (our default is 100 seats). The total number of meetings is 800 and we choose \mathcal{O}_3 as our meeting length. Clearly, the larger the room capacity, the more re-cooling energy is needed for all algorithms. Our algorithms greatly outperform RS for more than 50%.

We then study the general case where rooms are of non-uniform capacity. We show the results in Fig. 17. We see that the gain of Energy-RS is smaller. This is because, in each type of room capacity, we have a much smaller number of meeting choices. If one takes a closer look at Fig. 13 (a), we can see that the best performance arrives when the number of meetings is 800. When the number of meetings is 100, or 50, the gain is smaller. In our general case, we have 8 different types of rooms resulting in a smaller number of meetings in each type. Thus, the gain is smaller. We can summarize that the more meetings, the more choices; leading to more re-cooling energy needed; and a better performance of Energy-RS as compared to RS.

8. RELATED WORK

We are in an age where people are paying increasing attention to energy conservation around the world. Computer scientists study energy conservation of data centers [Raghavendra et al. 2008][Shang et al. 2010], and backbone routers [Zhang et al. 2010]. The general principle of these works is to turn off unnecessary usage of machines and reschedule their load. To assist data center monitoring, sensor network is used for energy sensing [Liang et al. 2009].

There are many efforts in developing smart homes and buildings. In [Jiang et al. 2009a][Jiang et al. 2009b], an energy auditing network is built. One main objective is to have a fine-grained granularity on electricity readings for all equipments. As a continuation, in [Dawson-Haggerty et al. 2010], sMAP is developed, which can record different physical readings and provide general interface for different applications. In [Hnat et al. 2011], a large scale sensor network for residential sensing was experimented for more than 20 homes.

Nowadays, many buildings can turn off facilities when people are not in presence. Many recent studies used sensors and actuators to collaboratively monitor buildings to assist the turn-off decisions [Lu et al. 2010a][Schor et al. 2009]. Smart-thermostat

[Lu et al. 2010b] developed motion sensors and door sensors to model the occupancy pattern of people at home. It will turn off the light, air-conditioning etc when people are absent. A similar system [Padmanabh et al. 2009] analyzes the occupancy against pre-booked conference rooms, so as to turn off unnecessary energy usage.

In a recent Proceedings of the IEEE special issue on cyber-physical systems, an invited paper [Aswani et al. 2012] presents a learning-based model predictive control scheme. It estimates room occupancy based on temperature measurements, i.e., it shows the impact of different number of people to the room temperature. The effect of human activities have been studied much earlier in [Wang and Jin 1998][Schell and Inthout 2001]. CO₂ is taken as an indicator of the occupancy to control the ventilation system. These schemes have a slow detection time, however. Therefore, real-time detection methods are proposed [Agarwal et al. 2010][Agarwal et al. 2011]. They choose a combination of magnetic reed switch door sensor and passive infrared sensor to build an occupancy platform and a duty-cycling HVAC system is developed. In [Erickson et al. 2010] a wireless camera sensor network is deployed to collect data related to occupancy. In a follow-up study, OBSERVE [Erickson et al. 2011] is proposed, in which a markov chain model is trained to predict the occupancy distribution and optimize ventilation level. With participation of people in the room, TempVote [Erickson and Cerpa 2012] saves energy while people are satisfied with the conditioning. EarlyOff [Ellis et al. 2012] predicts the schedule of room usage and turns off ACs before people leave the room.

In order to accurately control HVAC system and save energy, researchers use data-driven building energy modeling to provide information for control decision making. One focus is modeling and controlling the HVAC systems by investigation of physical factors. In [Oldewurtel et al. 2010][Henze et al. 2004] [Tashtoush et al. 2005][He et al. 2005] the HVAC systems are modeled where the weather conditions are taking into consideration. In [Deng et al. 2010] the thermal dynamics of a building is modeled. EnergyPlus [Ene 2010] is similar, yet it is one most sophisticated tool for thermal dynamics modeling in buildings. Both [Deng et al. 2010] and EnergyPlus require sophisticated inputs which may not be easily obtained in certain situations.

In traditional meeting scheduling algorithms, their main focus is finding a time and place when and where all participants are available [Chun et al. 2003]. In University Course Timetable Problems [Burke and Petrovic 2002][Lewis 2008][Socha et al. 2002], which are known NP-complete, the primary objective is finding a feasible course timetable for professors and students. Many objective/constraints, such as comfort, are considered in existing scheduling algorithms [Elmohamed et al. 1998][Carter 2001][Murray et al. 2007]. To the best of our knowledge, only few works consider energy-aware meeting scheduling algorithms[Majumdar et al. 2012], but they did not consider energy models which is main input of the algorithms.

Our work focuses on thermal inertia, which is a new concept that can save energy in buildings. We present a framework, which guides how to apply thermal inertia in energy conservation in rooms. In our framework, a good energy-temperature model (i.e., a thermal model) can surely improve the accuracy of room scheduling and increase energy conservation. Given that an accurate energy-temperature model is difficult to build, we discussed a few choices on the model, develop a simple model and conduct verification, though we admit that more experiments are needed to improve the confidence of the model or make adjustment to the model. We complete the framework with a set of room scheduling algorithms. Our work is a step towards understanding thermal inertia, and using it for energy conservation.

9. CONCLUSION AND FUTURE WORK

In this paper, we took the advantage of *Thermal Inertia*; that is, after a meeting ends in a room, the cool air will not immediate dissipate. We proposed a new room management system for energy conservation. We abstracted the framework for this kind of system. We extended sensor hardware (some of which can be used beyond this work) and designed a two tier sensor network. We develop an energy-temperature correlation model and validate the model with our sensor network in real-world experiment. We further developed efficient room scheduling algorithms. Comprehensive simulations on synthetic data and a real class and room configuration of The Hong Kong Polytechnic University were conducted.

As a first work in Thermal Inertia, our work has many limitations. First, in our current paper, we assume the meetings are determined in advance. This is true for university schedules. However, many companies/hotels/restaurants face online room booking. Second, other factors such as human and heat from electronic devices are not considered in current energy-temperature correlation model. We leave developing a more detailed model in future work. Third, in the current schedule, we assume the room capacity and facility are the constrains to meetings. We admit that there are other constraints, such as the distances between rooms so that people have enough time to go from one room to another. To facilitate future studies, we release an open source for our energy-temperature correlation model in MatLab[Yuan et al. 2011]. One can use our work to generate realistic input on energy consumptions for different room scheduling problems. Fourth, our electricity-meter can only measure energy usage of general air-conditioners. We plan to develop advanced meters for central controlled air-conditioners. Fifth, we only consider energy as our objective in scheduling meetings. There are other objectives, such as comfort which are also important in a schedule. We leave these objectives to future work in improving scheduling algorithms.

APPENDIX

Proof for theorem 2.1.

PROOF. It is easy to verify that calculating re-cooling energy consumption of a schedule is NP. Therefore, the minimum energy schedule problem is in NP class. To shown this problem is NP-complete, we reduce a job schedule problem to it. The former is proven NP-complete in [Arkin and Silverberg 1987]. The proven theorem is stated as follow: *Given a set $J = \{J_1, J_2, \dots, J_n\}$ of n jobs, job J_i has fixed start time and end time (s_i, t_i) . Given a set of k non-identical machines, every job J_i can only be processed on a subset of machines. It is NP-complete to determine whether all jobs can be processed.* This statement also indicates finding the minimum number of machines to process all jobs is NP-complete.

Given an instance (J, U, JU) : $J = \{J_1, J_2, \dots, J_n\}$ is the set of n jobs, $U = \{U_1, U_2, \dots, U_k\}$ is the set of k machines and $JU = \{JU_1, JU_2, \dots, JU_n\}$ is the family of subsets of U . J_i has fixed start time and end time (s_i, t_i) , and can only be processed on machines in JU_i . We construct a set of meetings $\mathcal{M} = \{M_1, M_2, \dots, M_n\}$ and a set of rooms $\mathcal{R} = \{R_1, R_2, \dots, R_k\}$. b_i and e_i for M_i are equal to s_i and t_i of J_i respectively. All meetings have same capacity requirement \bar{c} , all room have same capacity \bar{C} and $\bar{c} < \bar{C}$. For every meeting M_i , we create a type of facility f_i and M_i 's facility requirement $fr_i = \{f_i\}$. R_j has facility f_i if and only if $U_j \in JU_i$. Let all meetings have same T_t and let the outdoor temperature be a constant. We build a simplified energy-temperature correlation model: All rooms have same function $E(T_t, t)$ to calculate in-meeting energy consumption. Thus room change does not affect total in-meeting energy consumption. For every room R_j , $RE_j(T_t, t) = a_1$ if a meeting is the first meeting in the room, oth-

erwise $RE_j(T_t, t') = 0$ for following meetings in the room because following meetings take advantage of cooling air from the first meeting. a_1 is a positive constant.

We next show that by finding the minimum energy schedule S , we can find the minimum number of machines to process all jobs in polynomial time. Replacing (M_i, R_j) in S with (J_i, U_j) , we have a job schedule S' which is a valid schedule for all jobs. The number of rooms occupied in S is equal to the number of machines used in S' . The total re-cooling energy consumption of S is expressed as $RE_{total} = ha_1$ where h is the number of rooms occupied. Because a_1 is a positive constant, RE_{total} is minimum when h is minimized. In other words, the minimum energy schedule S uses minimum number of rooms. Thus S' use the minimum number of machines. \square

ACKNOWLEDGMENTS

The work described in this paper was supported in part by the National Natural Science Foundation of China (No. 61272464) and by Hong Kong PolyU/A-PK95.

REFERENCES

2010. Getting started with energyplus. Tech. rep., U.S. Department of Energy. <http://apps1.eere.energy.gov/buildings/energyplus/pdfs/gettingstarted.pdf>.
2010. Hong kong energy end-use data. Tech. rep., Electrical and Mechanical Service Department (EMSD), Hong Kong. <http://www.emsd.gov.hk/emsd/e.download/pee/HKKEUD2010.pdf>.
- AGARWAL, Y., BALAJI, B., DUTTA, S., GUPTA, R., AND WENG, T. 2011. Duty-cycling buildings aggressively: The next frontier in hvac control. In *Proceedings of the The 10th ACM/IEEE International Conference on Information Processing in Sensor Networks (IPSN'11)*. ACM/IEEE, Chicago, Illinois, USA.
- AGARWAL, Y., BALAJI, B., GUPTA, R., LYLES, J., WEI, M., AND WENG, T. 2010. Occupancy-driven energy management for smart building automation. In *Proceedings of the 2nd ACM Workshop On Embedded Sensing Systems For Energy-Efficiency In Buildings (BuildSys'10)*. ACM, Zurich, Switzerland.
- ARKIN, E. AND SILVERBERG, E. 1987. Scheduling jobs with fixed start and end times. *Discrete Applied Mathematics* 18, 1, 1 – 8.
- ASWANI, A., MASTER, N., TANEJA, J., CULLER, D., AND TOMLIN, C. 2012. Reducing transient and steady state electricity consumption in hvac using learning-based model predictive control. 100, 1, 240–253.
- BURKE, E. K. AND PETROVIC, S. 2002. Recent research directions in automated timetabling. *European Journal of Operational Research* 140, 2, 266 – 280.
- CARTER, M. 2001. A comprehensive course timetabling and student scheduling system at the university of waterloo. In *Practice and Theory of Automated Timetabling III*, E. Burke and W. Erben, Eds. Lecture Notes in Computer Science Series, vol. 2079. Springer Berlin / Heidelberg, 64–82.
- CHANTRASRISALAI, C., GHATTI, V., FISHER, D., AND SCHEATZLE, D. 2003. Experimental validation of the energyplus low-temperature radiant simulation. *ASHRAE Transactions* 109, 2, 614 – 623.
- CHUN, A., WAI, H., AND WONG, R. 2003. Optimizing agent-based meeting scheduling through preference estimation. *Engineering Applications of Artificial Intelligence* 16, 7C8, 727 – 743.
- DAWSON-HAGGERTY, S., JIANG, X., TOLLE, G., ORTIZ, J., AND CULLER, D. 2010. smap - a simple measurement and actuation profile for physical information. In *Proceedings of the 8th ACM Conference on Embedded Networked Sensor Systems (Sensys'10)*. ACM, Zurich, Switzerland.
- DENG, K., BAROOAH, P., P.G.MEHTA, AND S.P.MEYN. 2010. Building thermal model reduction via aggregation of states. In *American Control Conference (ACC), 2010*. 5118 –5123.
- ELLIS, C., SCOTT, J., HAZAS, M., AND KRUMM, J. C. 2012. Earlyoff: Using house cooling rates to save energy. In *Proceedings of the 4nd ACM Workshop On Embedded Sensing Systems For Energy-Efficiency In Buildings (BuildSys'12)*. ACM, Toronto, Canada.
- ELMOHAMED, M., CODDINGTON, P., AND FOX, G. 1998. A comparison of annealing techniques for academic course scheduling. In *Practice and Theory of Automated Timetabling II*, E. Burke and M. Carter, Eds. Lecture Notes in Computer Science Series, vol. 1408. Springer Berlin / Heidelberg, 92–112. 10.1007/BF-b0055883.
- ERICKSON, V., CARREIRA-PERPIÑÁN, M., AND CERPA, A. 2011. Observe: Occupancy-based system for efficient reduction of hvac energy. In *Proceedings of the The 10th ACM/IEEE International Conference on Information Processing in Sensor Networks (IPSN'11)*. ACM/IEEE, Chicago, Illinois, USA.

- ERICKSON, V. AND CERPA, A. E. 2012. Tempvote: Participatory sensing for efficient building hvac conditioning. In *Proceedings of the 4th ACM Workshop On Embedded Sensing Systems For Energy-Efficiency In Buildings (BuildSys'12)*. ACM, Toronto, Canada.
- ERICKSON, V., LIN, Y., KAMTHE, A., BRAHME, R., SURANA, A., CERPA, A., SOHN, M., AND NARAYANAN, S. 2010. Energy efficient building environment control strategies using real-time occupancy measurements. In *Proceedings of the 2nd ACM Workshop On Embedded Sensing Systems For Energy-Efficiency In Buildings (BuildSys'10)*. ACM, Zurich, Switzerland.
- GNAWALI, O., FONSECA, R., JAMIESON, K., MOSS, D., AND LEVIS, P. 2009. Collection tree protocol. In *Proceedings of the 7th ACM Conference on Embedded Networked Sensor Systems (Sensys'09)*. ACM, Berkeley, CA, USA.
- GOSWAMI, J. AND CHAN, A. 2011. *Fundamentals of Wavelets: Theory, Algorithms, and Applications*. Wiley Press.
- HE, M., CAI, W., AND LI, S. 2005. Multiple fuzzy model-based temperature predictive control for hvac systems. *Information Sciences* 169, 1C2, 155 – 174.
- HENZE, G. P., FELSMANN, C., AND KNABE, G. 2004. Evaluation of optimal control for active and passive building thermal storage. *International Journal of Thermal Sciences* 43, 2, 173 – 183.
- HNAT, T., SRINIVASAN, V., LU, J., SOOKOOR, T., DAWSON, R., STANKOVIC, J., AND WHITEHOUSE, K. 2011. The hitchhiker's guide to successful residential sensing deployments. In *Proceedings of the 9th ACM Conference on Embedded Networked Sensor Systems (Sensys'11)*. ACM, Seattle, USA.
- JIANG, X., DAWSON-HAGGERTY, S., DUTTA, P., AND CULLER, D. 2009a. Design and implementation of a high-fidelity ac metering network. In *Proceedings of the The 8th ACM/IEEE International Conference on Information Processing in Sensor Networks (IPSN'09)*. ACM/IEEE, San Francisco, USA.
- JIANG, X., LY, M., TANEJA, J., DUTTA, P., AND CULLER, D. 2009b. Experiences with a high-fidelity wireless building energy auditing network. In *Proceedings of the 7th ACM Conference on Embedded Networked Sensor Systems (Sensys'09)*. ACM, Berkeley, CA, USA.
- LEWIS, R. 2008. A survey of metaheuristic-based techniques for university timetabling problems. *OR Spectrum* 30, 167–190. 10.1007/s00291-007-0097-0.
- LI, T., LI, Q., ZHU, S., AND OGIHARA, M. 2002. A survey on wavelet applications in data mining. *ACM SIGKDD Explorations Newsletter* 2.
- LIANG, C., LIU, J., LUO, L., TERZIS, A., AND ZHAO, F. 2009. Racnet: A high-fidelity data center sensing network. In *Proceedings of the 7th ACM Conference on Embedded Networked Sensor Systems (Sensys'09)*. ACM, Berkeley, CA, USA.
- LIENHARD.IV, J. H. AND LIENHARD.V, J. H. 2003. *A heat transfer textbook,3rd edition*. Phlogiston Press.
- LU, J., BIRRU, D., AND WHITEHOUSE, K. 2010a. Using simple light sensors to achieve smart daylight harvesting. In *Proceedings of the 2nd ACM Workshop On Embedded Sensing Systems For Energy-Efficiency In Buildings (BuildSys'10)*. ACM, Zurich, Switzerland.
- LU, J., SOOKOOR, T., SRINIVASAN, V., GAO, G., HOLBEN, B., STANKOVIC, J., FIELD, E., AND WHITEHOUSE, K. 2010b. The smart thermostat: Using occupancy sensors to save energy in homes. In *Proceedings of the 8th ACM Conference on Embedded Networked Sensor Systems (Sensys'10)*. ACM, Zurich, Switzerland.
- MAJUMDAR, A., ALBONESI, D., AND BOSE, P. 2012. Occupancy-driven energy management for smart building automation. In *Proceedings of the 4th ACM Workshop On Embedded Sensing Systems For Energy-Efficiency In Buildings (BuildSys'12)*. ACM, Toronto, Canada.
- MURRAY, K., MLLER, T., AND RUDOV, H. 2007. Modeling and solution of a complex university course timetabling problem. In *Practice and Theory of Automated Timetabling VI*, E. Burke and H. Rudov, Eds. Lecture Notes in Computer Science Series, vol. 3867. Springer Berlin / Heidelberg, 189–209.
- OLDEWURTEL, F., PARISIO, A., JONES, C., MORARI, M., GYALISTRAS, D., GWERDER, M., STAUCH, V., LEHMANN, B., AND WIRTH, K. 2010. Energy efficient building climate control using stochastic model predictive control and weather predictions. In *American Control Conference (ACC), 2010*. 5100 –5105.
- PADMANABH, K., MALIKARJUNA, A., SEN, S., KATRU, S., KUMAR, A., PAWANKUMAR, S., VUPPALA, S., AND PAUL, S. 2009. isense: A wireless sensor network based conference room management system. In *Proceedings of the 1st ACM Workshop On Embedded Sensing Systems For Energy-Efficiency In Buildings (BuildSys'09)*. ACM, Berkeley, CA, USA.
- RAGHAVENDRA, R., RANGANATHAN, P., TALWAR, V., Z.WANG, AND ZHU, X. 2008. No power struggles: Coordinated multi-level power management for the data center. In *Proceedings of the 13th ACM Conference on Architectural Support for Programming Languages and Operating Systems (ASPLOS'08)*. ACM, Seattle, USA.
- SAUER, H., HOWELL, R., AND COAD, W. 2001. *Principles of heating, ventilating, and air conditioning*. Amer Society of Heating.

- SHELL, M. AND INTHOUT, D. 2001. Demand control ventilation using co2. *ASHRAE Journal* 42, 2, 18–29.
- SCHOR, L., SOMMER, P., AND WATTENHOFER, R. 2009. Towards a zero-configuration wireless sensor network architecture for smart buildings. In *Proceedings of the 1st ACM Workshop On Embedded Sensing Systems For Energy-Efficiency In Buildings (BuildSys'09)*. ACM, Berkeley, CA, USA.
- SHANG, Y., LI, D., AND XU, M. 2010. Energy-aware routing in data center network. In *Proceedings of the first ACM SIGCOMM workshop on Green networking (Green Networking '10)*. ACM, New Delhi, India.
- SOCHA, K., KNOWLES, J., AND SAMPELS, M. 2002. A max-min ant system for the university course timetabling problem. In *Ant Algorithms*, M. Dorigo, G. Di Caro, and M. Sampels, Eds. Lecture Notes in Computer Science Series, vol. 2463. Springer Berlin / Heidelberg, 63–77.
- TASHTOUSH, B., MOLHIM, M., AND AL-ROUSAN, M. 2005. Dynamic model of an hvac system for control analysis. *Energy* 30, 10, 1729 – 1745.
- TIAN, Z. AND LOVE, J. A. 2009. Energy performance optimization of radiant slab cooling using building simulation and field measurements. *Energy and Buildings* 41, 3, 320 – 330.
- USEnergy 2010. Energy in the united states. http://en.wikipedia.org/wiki/Energy_in_the_United_States.
- WANG, S. AND JIN, X. 1998. Co 2 -based occupancy detection for on-line outdoor air flow control. *Indoor and Built Environment* 7, 3, 165–181.
- WEI, W. W. 2005. *Time Series Analysis : Univariate and Multivariate Methods (2nd Edition)*. Addison Wesley.
- YUAN, Y., PAN, D., WANG, D., XU, X., PENG, Y., PENG, X., AND WAN, P. 2011. Developing an energy conservation room management system using thermal inertia (matlab package). Tech. rep. <http://www4.comp.polyu.edu.hk/~csyiyuan/projects/ECRMS-TOSN/ECRMS.html>.
- ZHANG, M., YI, C., LIU, B., AND ZHANG, B. 2010. Greente: Power-aware traffic engineering. In *Proceedings of the 18th IEEE International Conference on Network Protocols (ICNP'10)*. Kyoto, Japan.
- ZHOU, Y., WU, J., WANG, R., SHIOCHI, S., AND LI, Y. 2008. Simulation and experimental validation of the variable-refrigerant-volume (vrv) air-conditioning system in energyplus. *Energy and Buildings* 40, 6, 1041 – 1047.